

REVISION HISTORY			
REV.	DESCRIPTION	DATE	DRAWN BY
1	ORIGINAL PRINT	5/18/2022	T. JORGENSEN

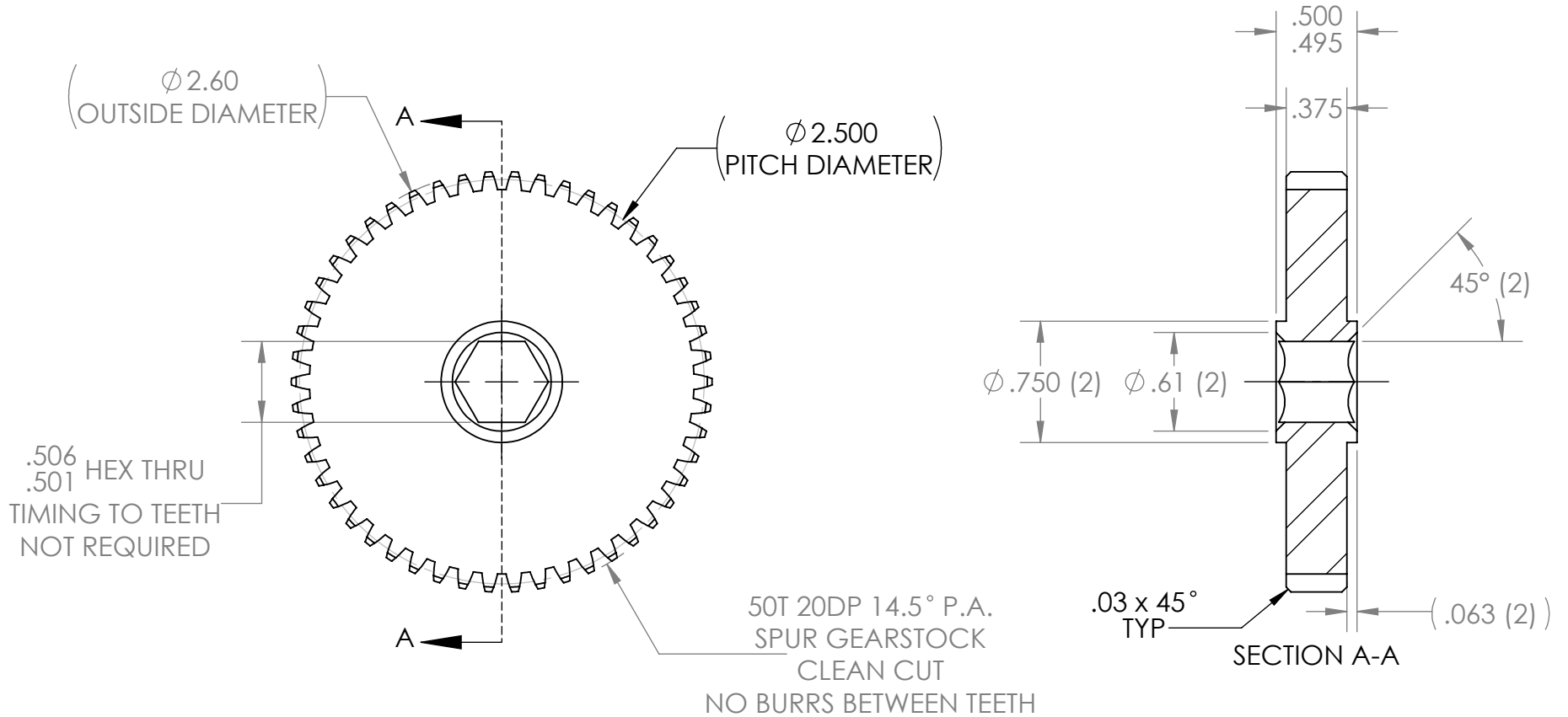

\*\*\* SEE CAD FOR ADDITIONAL TOOLPATH INFO\*\*\*

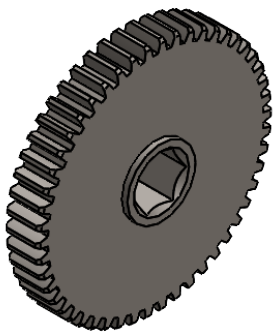

UNLESS OTHERWISE SPECIFIED:		COMMENTS:				
<b>DIMENSIONS ARE IN INCHES</b>		DUAL DIMENSIONS ARE IN MILLIMETERS.				
TOLERANCES:		BREAK ALL SHARP EDGES.		TITLE:		
FRACTIONAL	$\pm 1/16$			50T 20DP 14.5PA		
ANGULAR: MACH	$\pm 1^\circ$			0.500IN HEX BORE GEAR		
ANGULAR: BEND	$\pm 5^\circ$			SIZE	DWG. NO.	REV
ONE PLACE DECIMAL	$\pm 0.1$			<b>A</b>	am-4715	1
TWO PLACE DECIMAL	$\pm 0.01$					
THREE PLACE DECIMAL	$\pm 0.005$			SCALE: 1:1		SHEET 1 OF 1
FOUR PLACE DECIMAL	$\pm 0.0005$					
MATERIAL	4140 STEEL	CHECKED	NAME	DATE		
FINISH	DEBURRED ZINC PLATED	ENG APPR.	NL	5/23/22		
DO NOT SCALE DRAWING		MFG APPR.				
		Q.A.				